

ASTORINO

Maintenance Manual

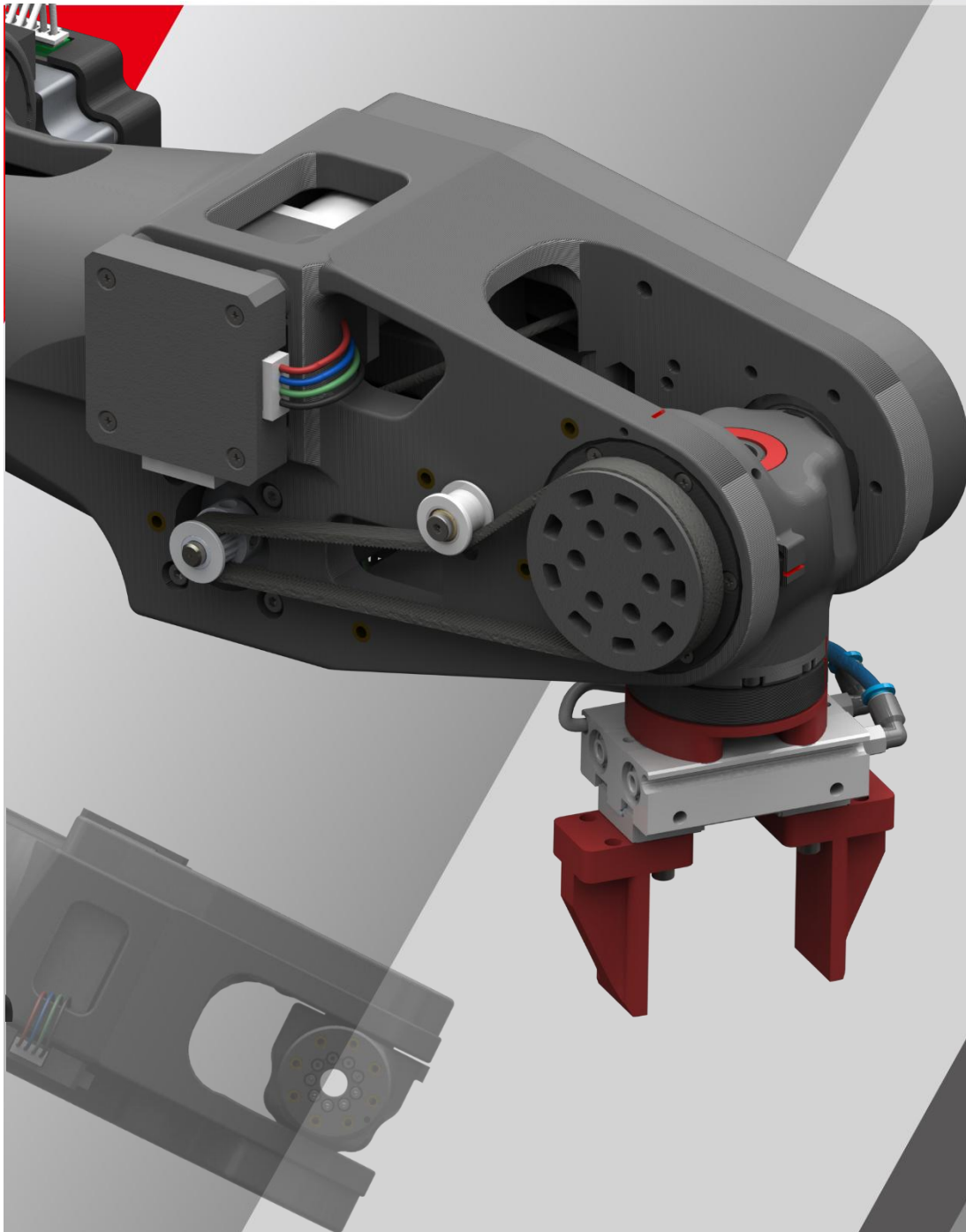

Preface

This manual describes the maintenance of the 6-axis robot "astorino" and the associated "astorino" software.

This is an original documents and is not translated.

The ASTORINO is a learning robot specially developed for educational institutions. Pupils and students can use the ASTORINO to learn robot-assisted automation of industrial processes in practice.

ASTORINO Maintenance Manual

1. The "astorino" software included with the ASTORINO is licensed for use with this robot only and may not be used, copied or distributed in any other environment.
2. Kawasaki shall not be liable for any accidents, damages, and/or problems caused by improper use of the ASTORINO robot.
3. Kawasaki reserves the right to change, revise, or update this manual without prior notice.
4. This manual may not be reprinted or copied in whole or in part without prior written permission from Kawasaki.
5. Keep this manual in a safe place and within easy reach so that it can be used at any time. If the manual is lost or seriously damaged, contact Kawasaki.

Copyright © 2025 by KAWASAKI Robotics GmbH.

All rights reserved.

Symbols

Items that require special attention in this manual are marked with the following symbols.

Ensure proper operation of the robot and prevent injury or property damage by following the safety instructions in the boxes with these symbols.



WARNING

Failure to observe the specified contents could possibly result in injury or, in the worst case, death.

[ATTENTION]

Identifies precautions regarding robot specifications, handling, teaching, operation, and maintenance.



WARNING

- 1. The accuracy and effectiveness of the diagrams, procedures and explanations in this manual cannot be confirmed with absolute certainty. Should any unexplained problems occur, contact Kawasaki Robotics GmbH at the above address.**
- 2. To ensure that all work is performed safely, read and understand this manual. In addition, refer to all applicable laws, regulations, and related materials, as well as the safety statements described in each chapter. Prepare appropriate safety measures and procedures for actual work.**

Paraphrases

The following formatting rules are used in this manual:

- For a particular keystroke, the respective key is enclosed in angle brackets, e.g. <F1> or <Enter>.
- For the button of a dialog box or the toolbar, the button name is enclosed in square brackets, e.g. [Ok] or [Reset].
- Selectable fields are marked with a square box .
If selected a check mark is shown inside the symbol .

Date	Change Description
2025/03/03	Added information about authorized personnel Added document number
2025/03/26	Added compressed air warning

ASTORINO Maintenance Manual

List of contents

Preface	I
Symbols	1
Paraphrases	2
List of contents	3
1 Nomenclature in this manual	4
2 Overview of ASTORINO	4
3 Basic maintenance operations	5
4 Belt tension adjustment JT5/JT6	6
5 JT1 backlash compensation	8
6 JT4 backlash compensation	9
7 Gears lubrication	11
7.1 JT1 lubrication	11
7.2 JT4 lubrication	12
8 Manual JT2 and JT3 brake release	13
9 JT1 shaft clutch check	14
10 JT2 and JT3 clutch check	15
10.1 Gearbox clutch	15
10.2 Brake clutch	16
11 Manufacturer information	17

1 Nomenclature in this manual

The author of the manual tries to use generally valid terminology while achieving the greatest possible logical sense. Unfortunately, it must be noted that the terminology is reversed depending on the point of view when considering one and the same topic. Also it is to be stated that in the course of the computer and software history terminologies developed in different way. One will find therefore in a modern manual no terminologies, which always satisfy 100% each expert opinion.

2 Overview of ASTORINO

The ASTORINO is a 6-axis learning robot developed specifically for educational institutions such as schools and universities. The robot design is based to be 3D printed with PET-G filament. Damaged parts can be reproduced by the user using a compatible 3D printer.

Programming and control of the robot is done by the "astorino" software.

The latest software version and 3D files can be downloaded from the KAWASAKI ROBOTICS FTP server:

<https://ftp.kawasakirobot.de/Software/Astorino/>

Just like Kawasaki's industrial Robots the ASTORINO is programmed using AS language. Providing transferable programming skills from the classroom to real industrial applications.

3 Basic maintenance operations

Action	Period of time	Daily inspection	2500 hours
Physical damage		☑	☑
Gear backlash and abnormal sounds during operation		☑	☑
JT5/JT6 belt tension check			☑
Replenish gear lubrication			☑
Check the internal wires of the robot			☑
Checking the tightening torque of the assembly screws			☑
Check E-STOP functionality			☑
Motors clutch check			☑

! WARNING

All listed below operations must be performed by authorized and trained personnel. Please read Safety Manual and make sure that the robot is firmly installed on a solid surface

Authorized personnel must be approved by Astor or Kawasaki Robotics company or their partners. Authorized personnel should also be trained how to deal with electronic equipment and must have all necessary legislations to work with electric equipment.

! WARNING

Do not unplug pressure inlet without bleeding off pressure source first!



4 Belt tension adjustment JT5/JT6

To correct the tension of the JT5/JT6 belts follow listed below steps:

- Turn the robot OFF,
- Remove the cover of JT5 or JT6 belt

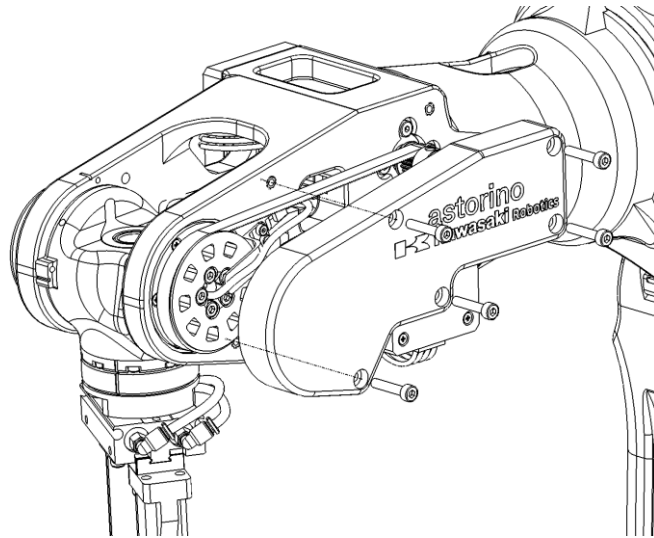

- Using an Allen key, loosen the tensioning pulley tightening screw

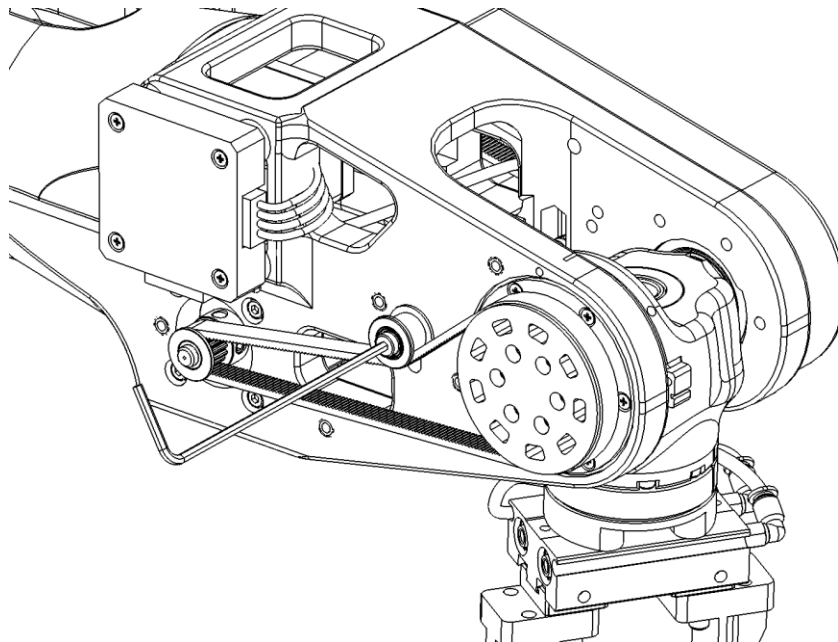

ASTORINO Maintenance Manual

- Tension the belt by moving the wheel down (JT5) or up (JT6)

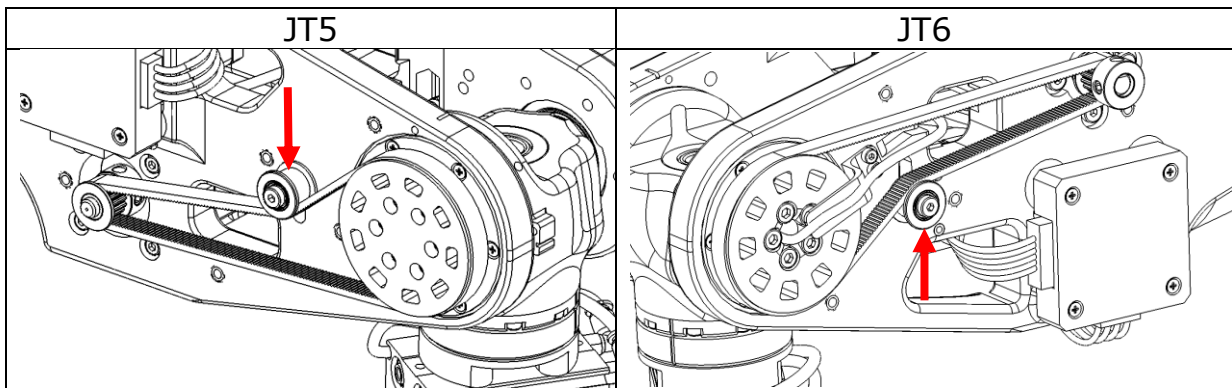

- Tighten the pulley that it can freely spin, but cannot move up or down,
- Close the covers,

5 JT1 backlash compensation

If there is a backlash on JT1 follow below procedures to cancel it out:

- During normal operations of the robot find the spot on JT1 where the backlash is the biggest,
- Turn off astorino,
- Move JT1 to this found spot by hand,
- Loosen the four M4 screws that hold the JT1 motor,

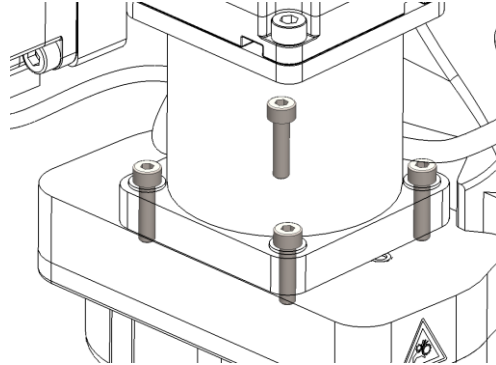

- Push JT1 gearbox towards the center of the robot

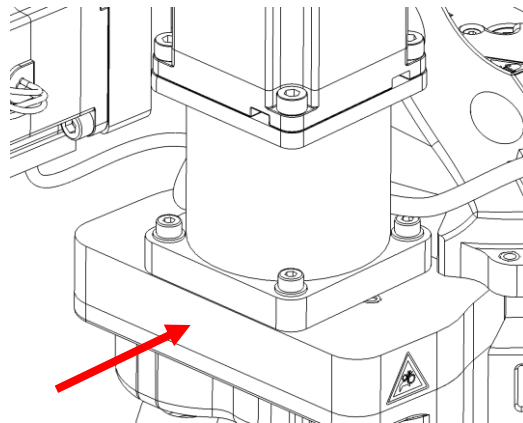

- Holding the tension tighten at least two M4 screws,
- Tighten the rest of the screws
- Turn on the robot and check for unnormal operations,

[ATTENTION]

If this procedure did not cancel out backlash instead of push, pull the JT1 gearbox outward.

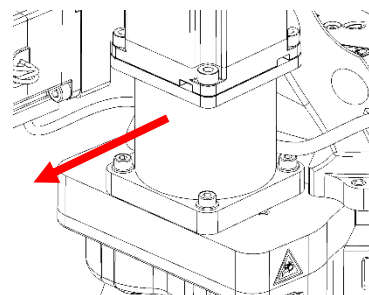

6 JT4 backlash compensation

If there is a backlash on JT4 follow below procedures to cancel it out:

- During normal operations of the robot find the spot on JT4 where the backlash is the biggest,
- Turn off astorino,
- Move JT4 to this found spot by hand,
- Remove the JT4 motor cover

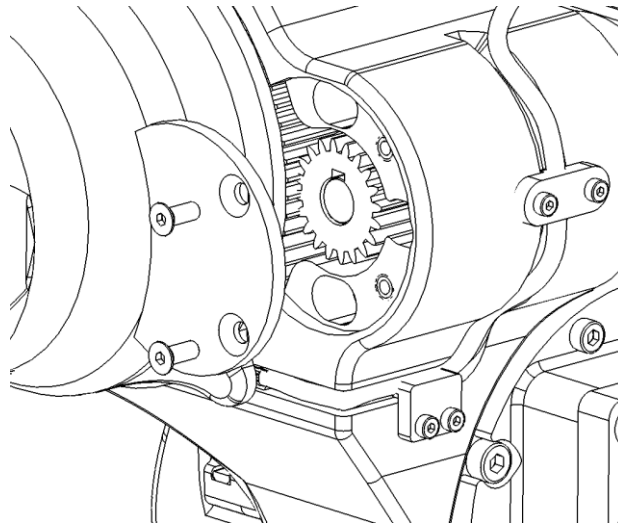

- Loosen the three M4 screws that hold the JT4 motor,

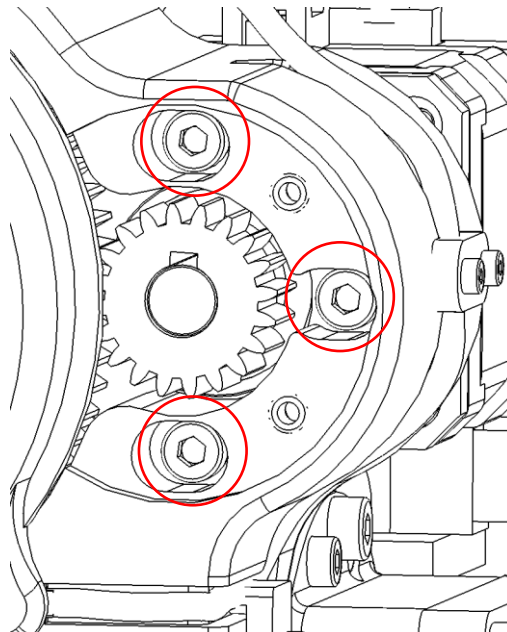

ASTORINO Maintenance Manual

- Push JT4 gearbox towards the center of the robot

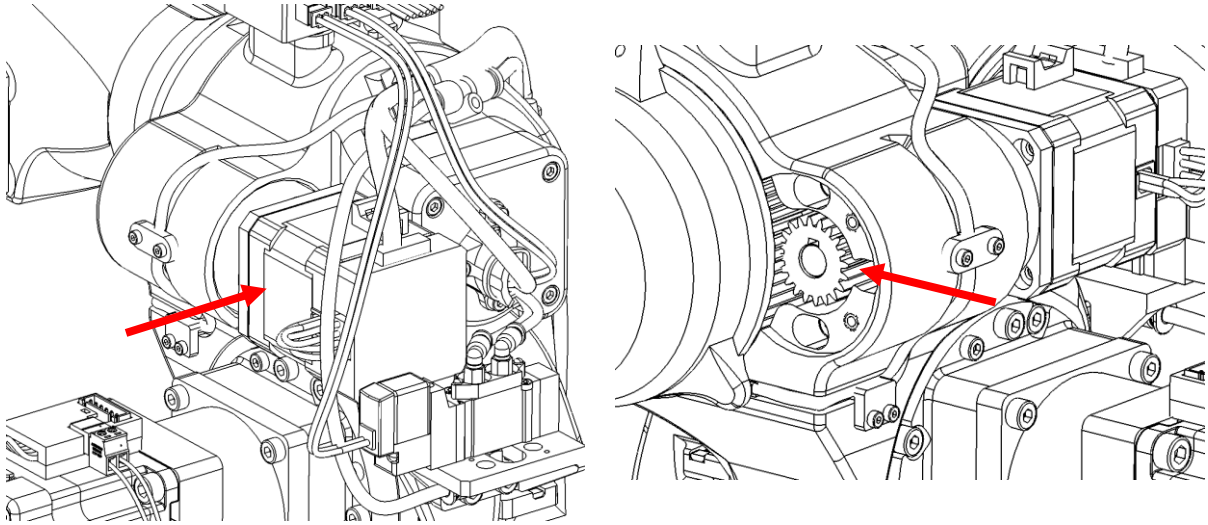

- Holding the tension tighten at least one M4 screws,
- Tighten the rest of the screws
- Turn on the robot and check for unnormal operations,

7 Gears lubrication

For gears lubrication you can use petrolatum (Vaseline) or silicone based grease.

7.1 JT1 lubrication

To lubricate the JT1 gears follow below steps:

- Remove the JT1 gears cover:

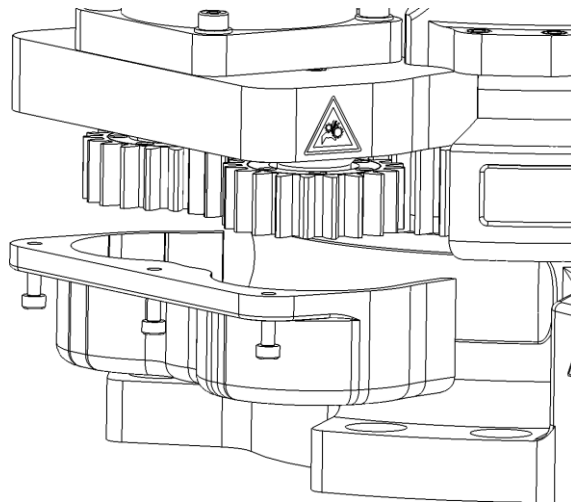

- Put small amount of a lubricant on the gears,

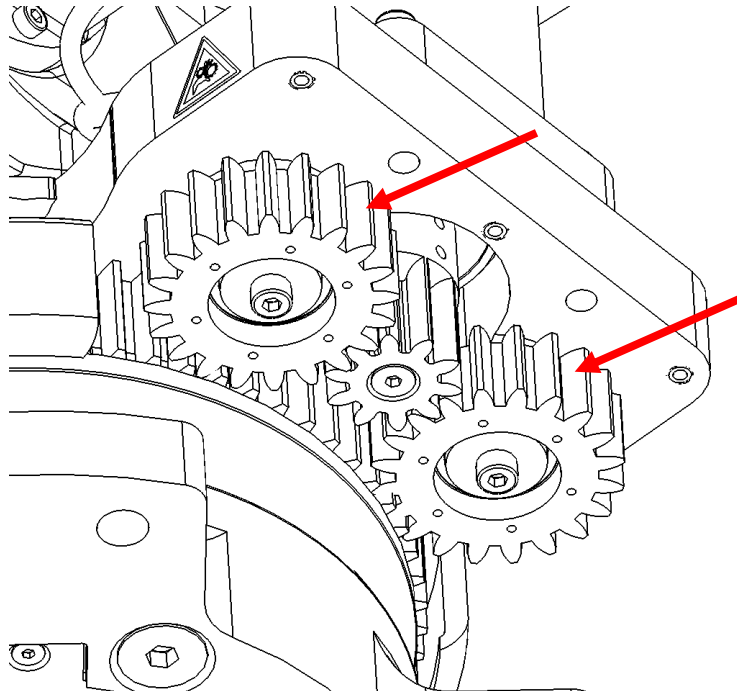

- Move JT1 by hand so the lubricant is spread,
- Wipe off excess,
- Close the cover

7.2 JT4 lubrication

To lubricate the JT4 gears follow below steps:

- Remove the JT4 gears cover:

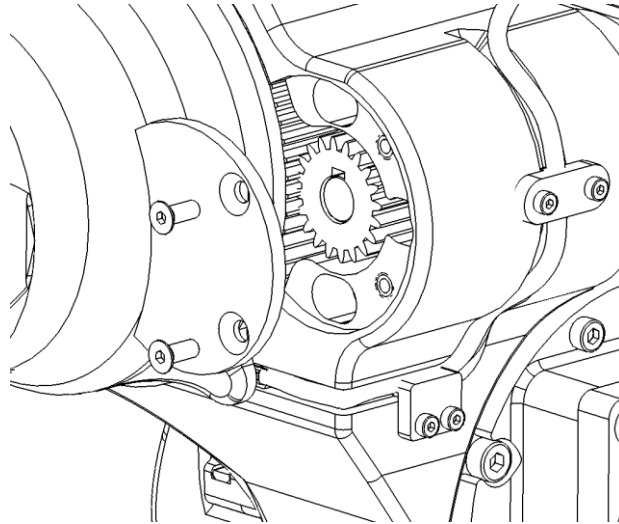

- Put small amount of a lubricant on the gears,

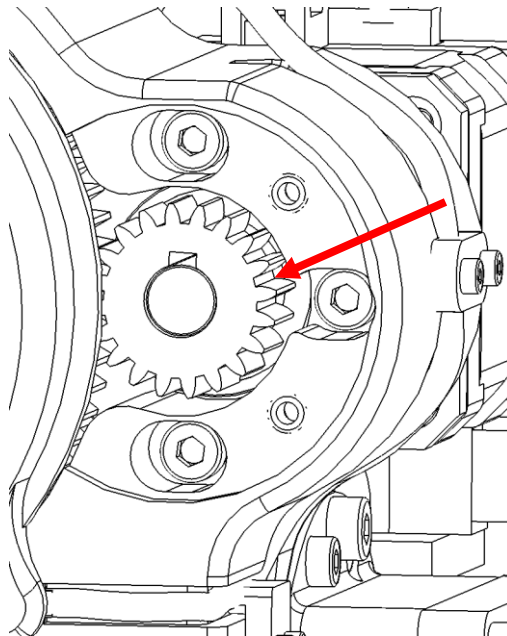

- Move JT4 by hand so the lubricant is spread,
- Wipe off excess,
- Close the cover

8 Manual JT2 and JT3 brake release

WARNING

Be careful during this procedure! After brake release the arm will fall and may cause damage to yourself or the robot!

To release JT2 or JT3 brakes please follow listed below steps:

- Turn power ON,
- Locate small black box on that is installed on JT2 or JT3 motor,

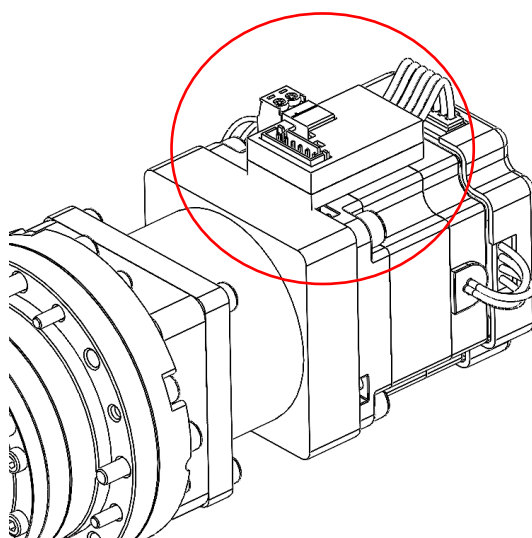

- Support robot arm by hand,
- Press small button with non-metal object,

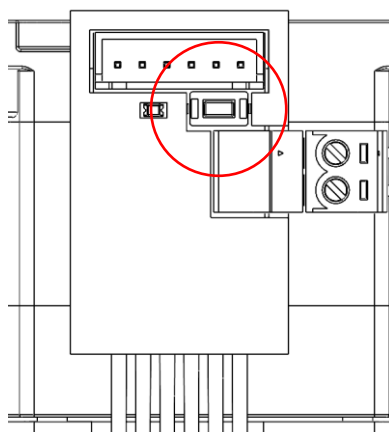

- Brake is released and arm can be moved.

9 JT1 shaft clutch check

JT1 gearbox clutch is tighten with two M4 screws

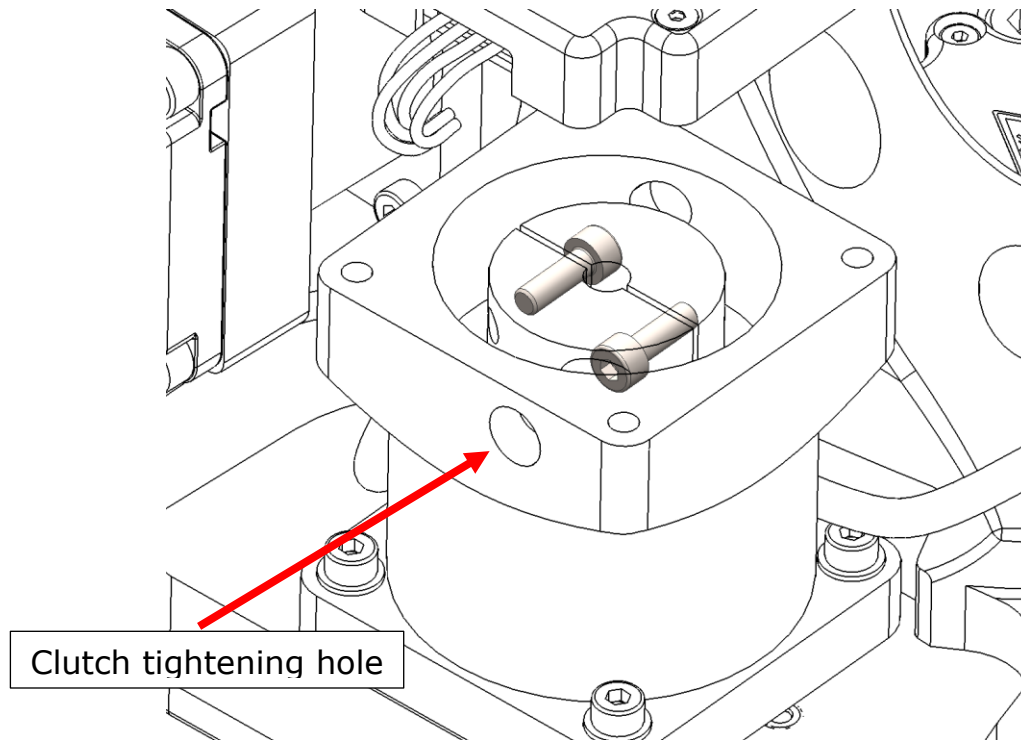

To check the tightness of the clutch screws follow listed below steps:

- Turn off power,
- Rotate by hand JT1 axis until in the clutch tightening hole will be visible M4 screw head,
- Using Allen wrench tighten the screw (2.8 Nm),
- Rotate by hand JT1 axis until in the clutch tightening hole will be visible second M4 screw head,
- Using Allen wrench tighten the screw (2.8 Nm),

10 JT2 and JT3 clutch check

JT2 and JT3 motor systems are the same. There are two clutches that needs to be checked.

10.1 Gearbox clutch

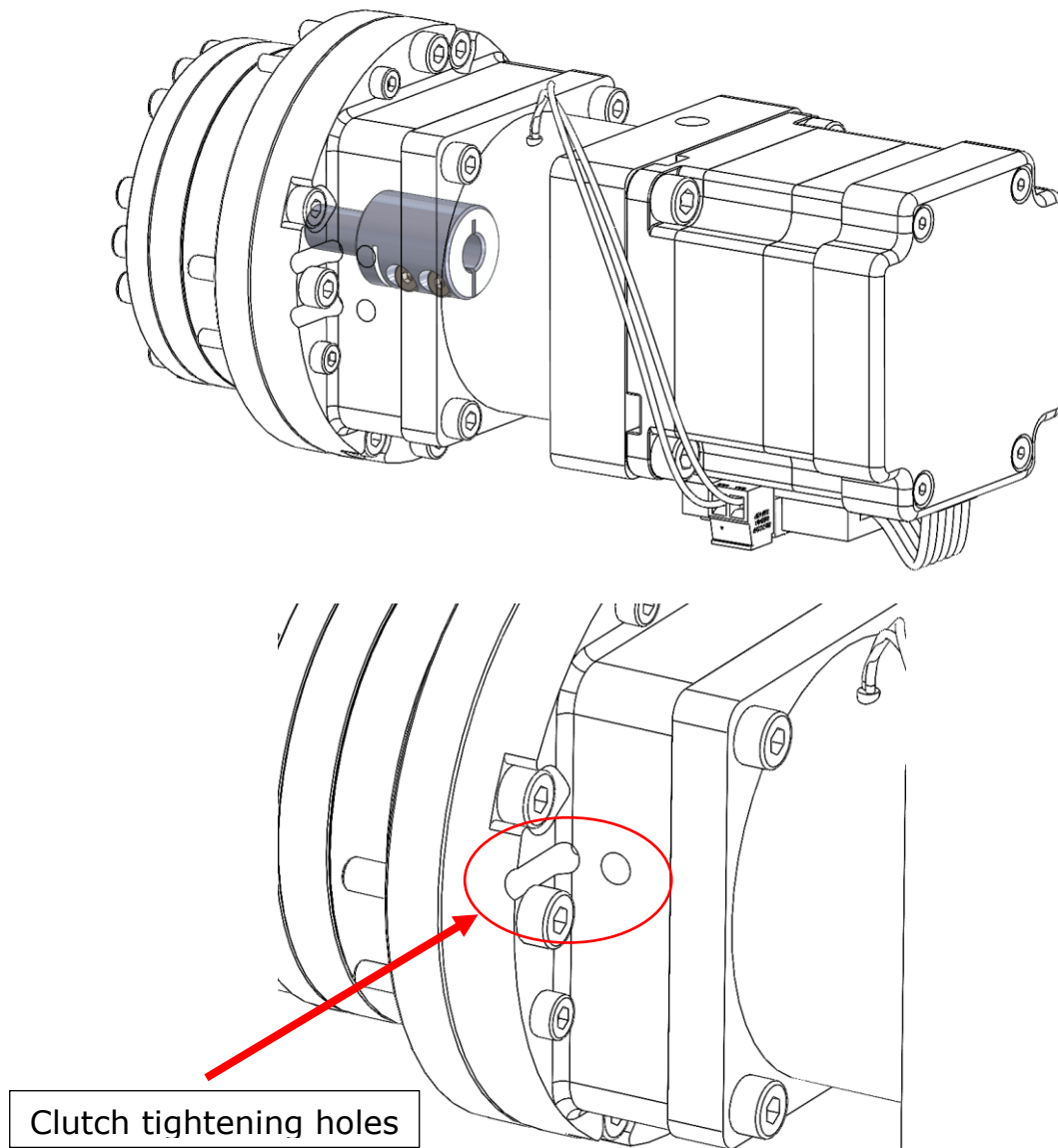

To check the tightness of the clutch screws follow listed below steps:

- Turn ON power,
- Release JT2/3 brake,
- Rotate by hand JT2/3 axis until in the clutch tightening hole will be visible M3 screws heads,
- Using Allen wrench tighten the screws (1.3 Nm),

10.2 Brake clutch

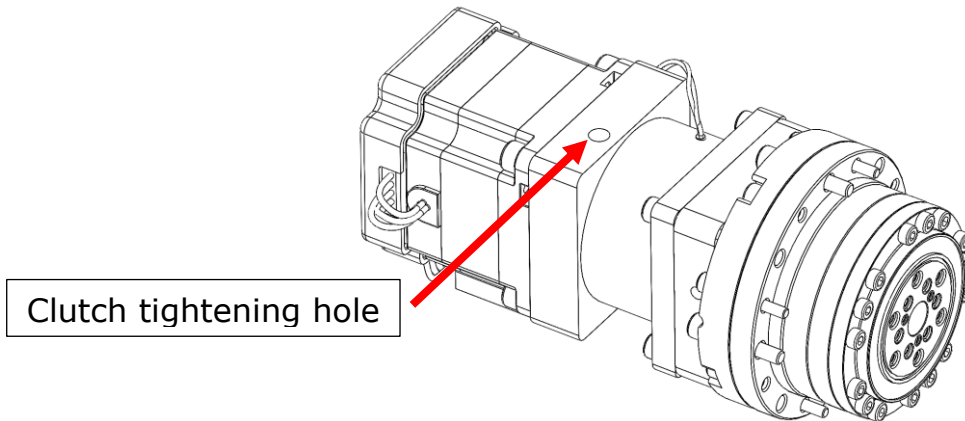
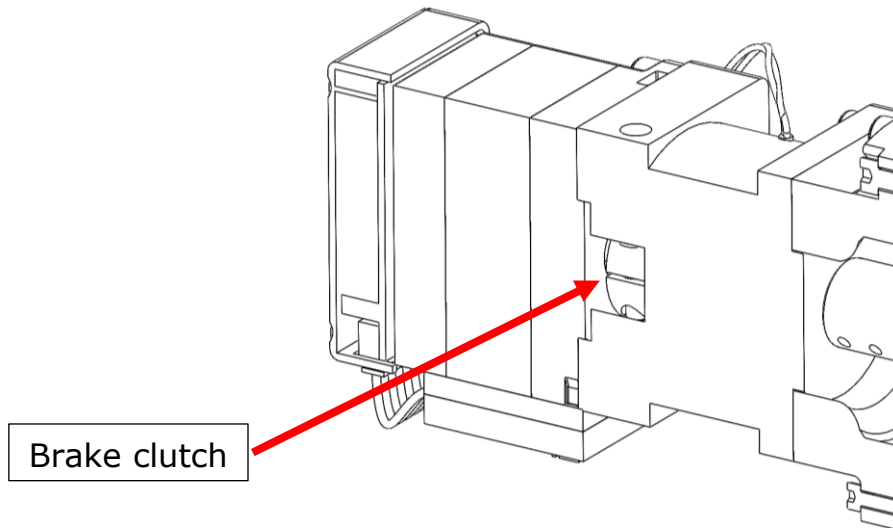

To check the tightness of the clutch screws follow listed below steps:

- Turn ON power,
- Release JT2/3 brake,
- Rotate by hand JT2/3 axis until in the clutch tightening hole will be visible M4 screw head,
- Using Allen wrench tighten the screws (2.8 Nm),

11 JT2 and JT3 screws check

11.1 JT2 arm screws check

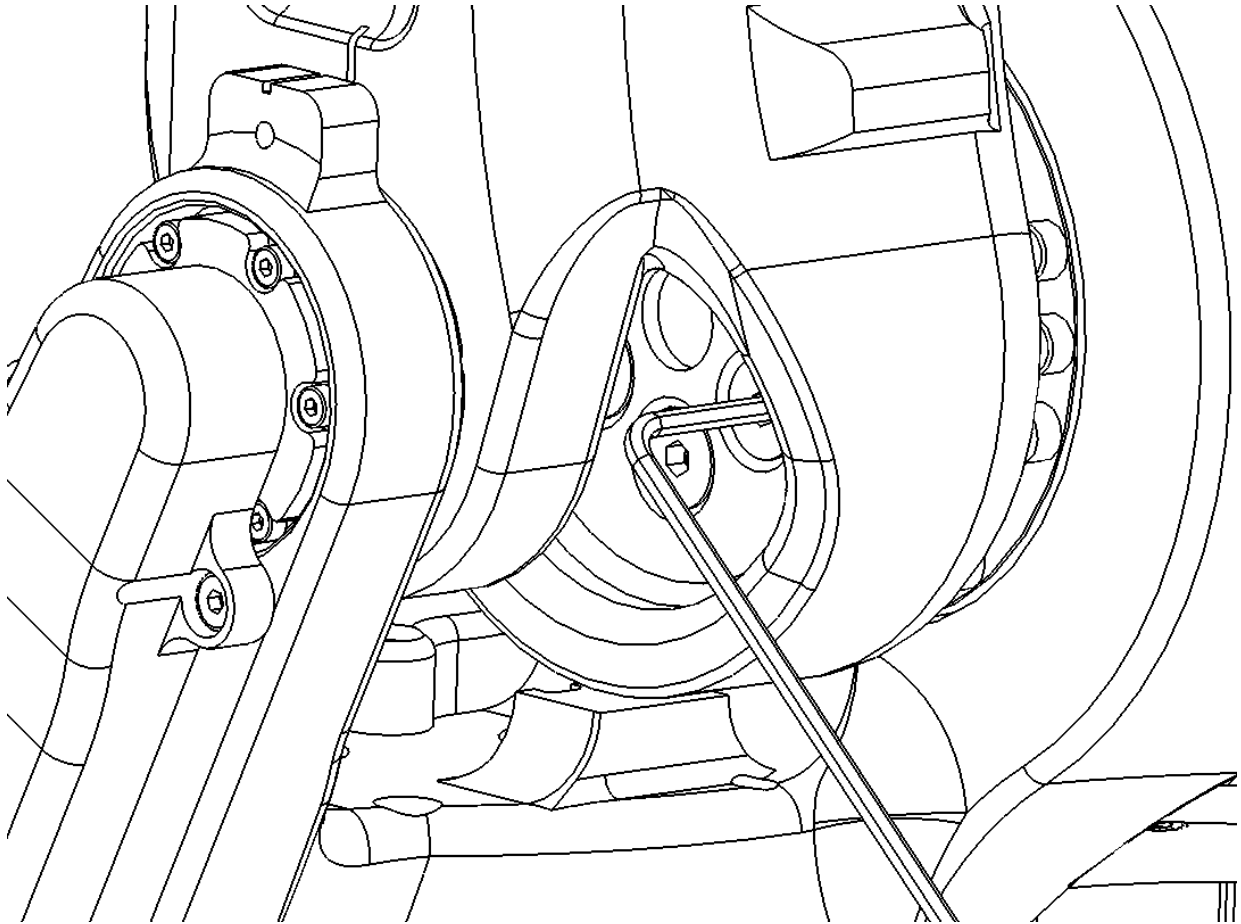

Using Allen wrench tighten the screws (5.5 Nm)

11.2 JT3 arm screws check

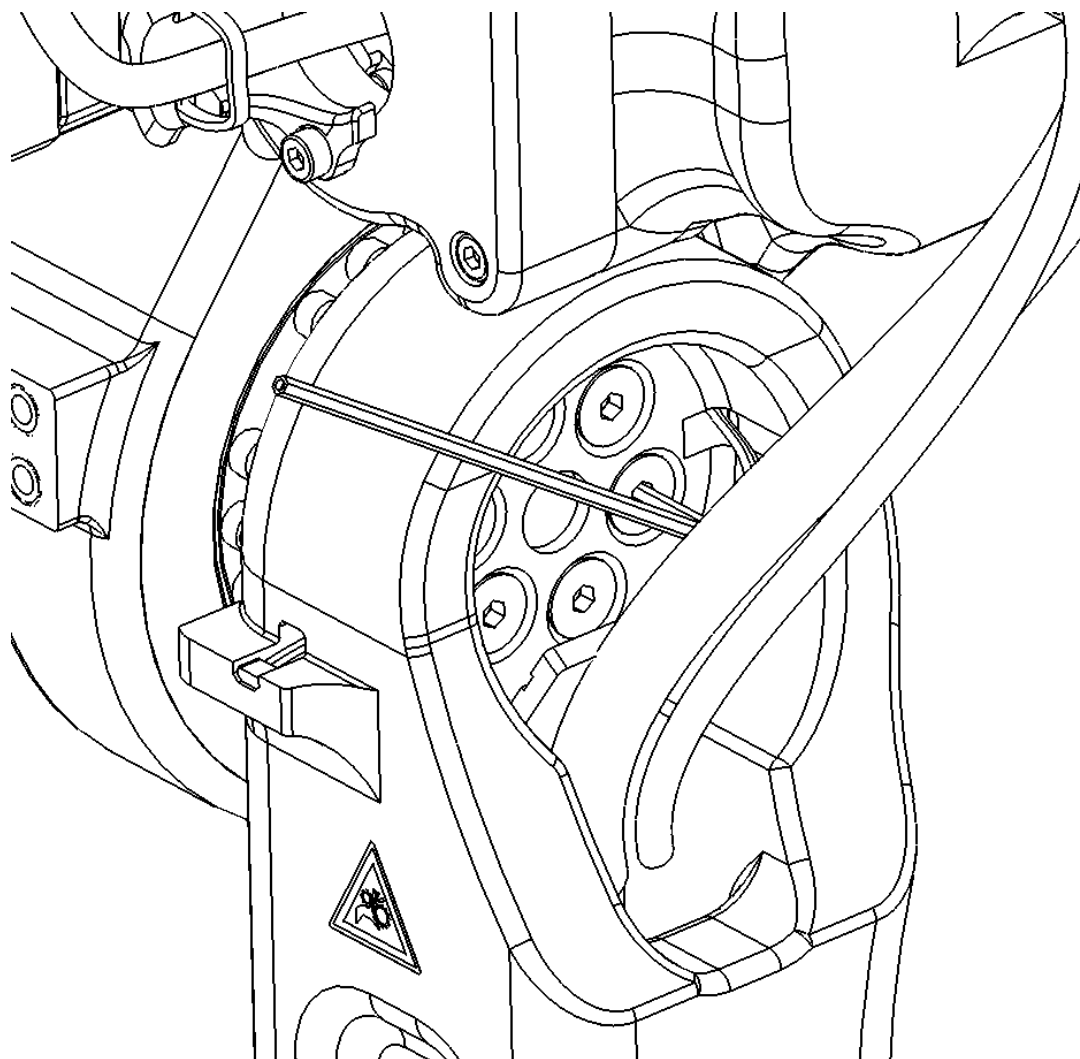

Using Allen wrench tighten the screws (5.5 Nm)

12 Manufacturer information

For further questions, contact Kawasaki Robotics support.

Contact:

Kawasaki Robotics GmbH

tech-support@kawasakirobot.de

+49 (0) 2131 – 3426 – 1310

Kawasaki Robot
Maintenance Manual

2025-03: 5th Edition

Publication: KAWASAKI Robotics GmbH

Copyright © 2025 by KAWASAKI Robotics GmbH.
All rights reserved.